

Design and Control Analysis of $(2n+2 / 0 \leq n \leq 3)$ Wheels Mobile Rover Using PI Controller

Amel ZERIGUI¹, Xiang WU² & Zong-Quan DENG³

¹School of Mechanical Engineering, Harbin Institute of Technology Harbin, Heilongjiang 150001, China
E-mail: zerigui_amel@hotmail.com

²School of Mechanical Engineering, Harbin Institute of Technology Harbin, Heilongjiang 150001, China
E-mail: xiangwu@hit.edu.cn

³School of Mechanical Engineering, Harbin Institute of Technology Harbin, Heilongjiang 150001, China
E-mail: denzq@hit.edu.cn

Received: 09th March 2017 Revised: 13th April 2017 Accepted: 11th June 2017

Abstract: Control $(2n+2 / 0 \leq n \leq 3)$ Wheels Mobile Rover is generated by using (proportional-integral) PI controller. In this paper we show the analytical study of the control design of group of rovers presented by two wheels rover, four wheels rover, six wheels rover and eight wheels rover. The design analysis of the close loop of the control system in continues and discrete times are showed. By using MATLAB simulation we show the transfer function simulation which is presented in linear and nonlinear design. Simulation results are also presented in this paper.

Keywords: Wheels Mobile Rover, PI controller, Tustin method, Digital control system, linear system.

1. INTRODUCTION

Wheels mobile robot has wide application such as transportation, education experiments [1], and space exploration [3]. The control system of wheels mobile rover is our interest. In this report we described the control system presented by 2, 4, 6, 8 wheels rover process which is based in FLEX devise FPGA EPF10K10 and digital signal processing DSP. In related research, the controller algorithms are several such as PID controller which is used for 2 wheels rover presented by Super Mario [2], Fuzzy and PID controller is used for 4 wheels rover for Pioneer AT-3 [4], Zaurus is six wheels rover controlled by neuron network and PID controller, finally remote controller is used to control Lunokhod which is 8 wheels mobile rover [9]. In our project we combine the control system of all these rovers in common control system.

In this paper we present the design and control analysis system of $(2n + 2 / 0 \leq n \leq 3)$ Wheels Mobile Rover by using (proportional-integral) PI controller. In our implementation we divided this report work to four important parts the second one we show the mechanical design of the system, the third section we explain the electrical implementation and the algorithm used of the design and in four we show the control system analyzed in continues time as linear design. And the second point in the fourth section we studied the system in the discrete time

as nonlinear system. The goal of this method is to use some results of the linear design in the nonlinear design in discrete time because we have some difficulties to control $(2n+2 / 0 \leq n \leq 3)$ Wheels Mobile Rovers in discrete time. In this section we will present the linear design by showing the open and close loop function of the system. We present also nonlinear system analysis in discrete time. In each section in this paper we obtain result by using MATLAB simulation. Finally we compare these results in section five presented by conclusion.

2. MECHANICAL DESIGN

The rover mechanical design can separate in two important parts; the first one is the body which is not less important that the mechanical design of the wheels. The $(2n + 2 / 0 \leq n \leq 3)$ Wheels Mobile Rover are robot or rover which has 2 wheels, 4 wheels, 6 wheels, or 8 wheels which are our interest, in fact the mechanical design of each wheel is similar to others in same rover which is related to the environment. But we can find it difference between rover to others [7, 8]. Fig. 1 shows the $(2n + 2 / 0 \leq n \leq 3)$ Wheels Mobile Rover. Unfortunately the mechanical design of the rovers is not our goal, that we give the importance to these rovers to design their hardware and their control system. In general case each wheel related to the motor, motor driver, encoder and some times some sensors such as cameras for this global hardware we can design a common hardware and common control system even the difference of mechanical design.

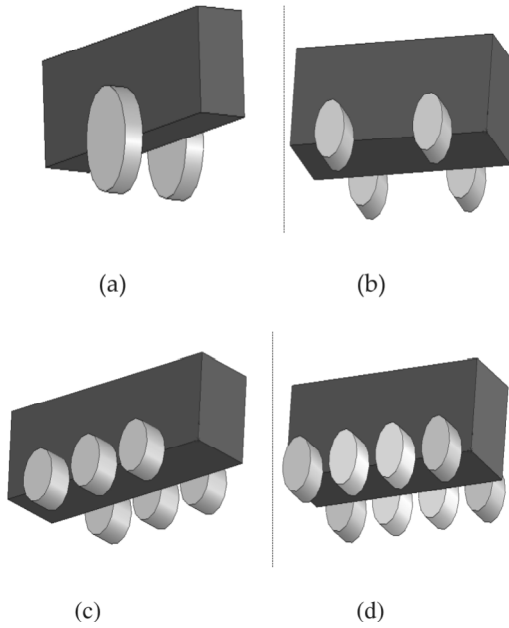

Figure 1: (a) Two wheels rover (b) Four wheels rover (c) Six wheels rover (d) Eight wheels rover

3. HARDWARE DESIGN

3.1 Electrical Design

The hardware design of our system will show in this section, the main components used in this design is field programming gate array FPGA FLEX 10k10 with digital signal processing DSP (TMS 320 LF 2407) which is connected to the communication board. $(2n+2 / 0 \leq n \leq 3)$ Wheels Mobile Rover as presented in above has 8 A/D and D/A converter which are connected with FPGA and motor driver. The hardware also includes the communication board presented by Bluetooth circuit. Fig. 2 shows the control system overview. The control system design needs 4 rovers have 2 or 4 or 6 or 8 wheels. We tried to combine 4 systems in same hardware and same software with low cost and high

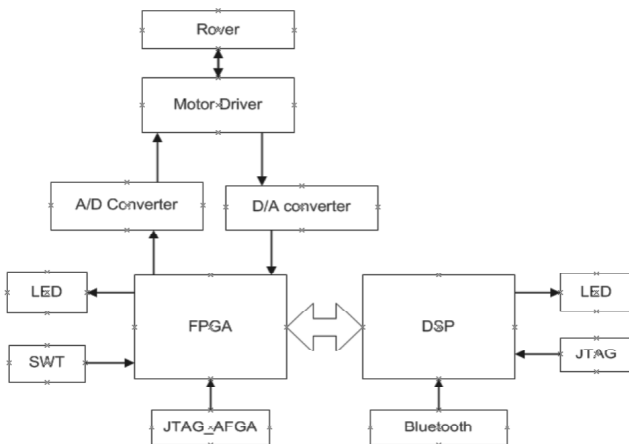

Figure 2: Presents the Control System Overview

performance. In the design we use DIP switches to select the rover used. So in same system we combine 4 sub hardwares, and 4 sub soft wares. The power supply in the electrical board has two sources one for 24 V for the motors and 5 V for FPGA. We convert 5 V to 3.3 V to control the DSP.

3.2 Algorithm Based in the System

The control system algorithm of $(2n + 2 / 0 \leq n \leq 3)$ wheels rover based on the FPGA electrical board presented by the state machine. The result of the state machine is speed and direction information for each motor. There are two processors in the control system FPGA and DSP. By using a C language to write a program download it in the DSP we control the first part of the board but this program is not enough so other side we use VHDL language to write program to download it in the FPGA chip through the byte blaster via JTAG. A system diagram of the controller software can be found in Figure 3.

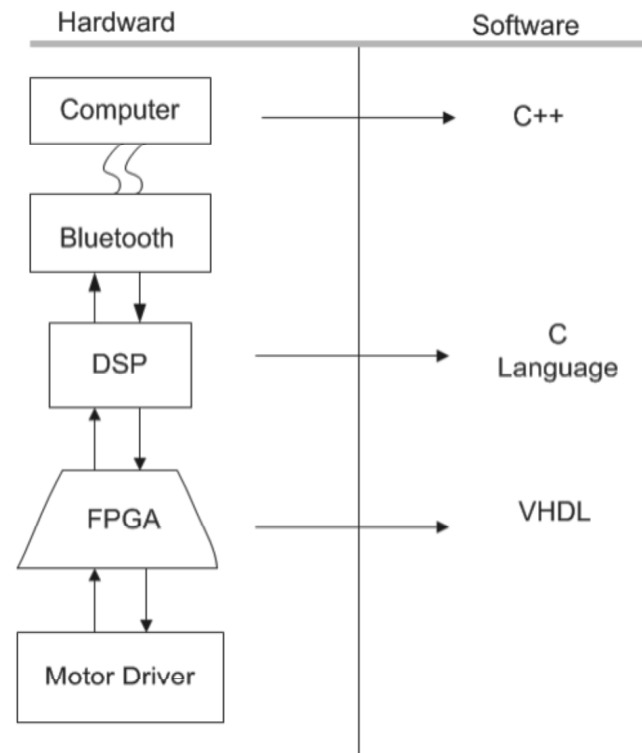

Figure 3: Overview of the Software Implementation

4. CONTROL DESIGN

4.1 Linear Design

In this section we present the control system of $(2n+2 / 0 \leq n \leq 3)$ Wheels Mobile Rover which was firstly studied as a linear system in continuous time. And then we studied the system as digital system in discrete time signal processing.

Open loop transfer function for DC motor: Our system consist 4 subsystems presented by two wheels rover, four wheels rover, six wheels rover and eight wheels rover. Every wheel consists a DC motor, in our design we choose a Maxon motor cause it advantages such us it useful in space exploration and this is one of our aims. Gordon Wyeth in [6] shows the open loop transfer function for Maxon motor. So we assume the transfer function presented in [6] is our transfer function of our system.

$$G = \frac{\omega(s)}{V(s)} = \frac{1.14 \times 10^7}{s^2 + 3339s + 59700} \quad (1)$$

PI controller: Our process is controlled using proportional-integrated (PI) controller. In many cases the PI controller is used to keep the bandwidth low and also to reduce the steady- state error [10, 5]. Equation 2 presents the output in the time domain. Where equation 3 shows the PI transfer function ($k_D = 0$). From [1] we also take the value of k_p and k_i to obtain good control system.

$$u(t) = k_p + k_i \int e(t)dt \quad (2)$$

$$G(s) = k_p + \frac{k_i}{s} \quad (3)$$

Figure 4 shows the block diagram of $(2n + 2 / 0 \leq n \leq 3)$ Wheels Mobile Rover.

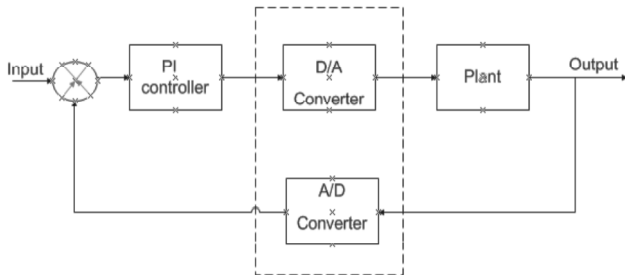

Figure 4: The Block Diagram of the System

A/D and D/A transfer function in linear design: As shown in fig 5 the block diagram of the system includes A/D and D/A converters. The hardware design of the rovers includes 8 A/D converters and 8 D/A converters, connected to the FPGA. But we only 2 A/D and 2 D/A converters are used in 2 wheels mobile rover, 4 converters are used for 4 wheels rovers, 6 converters used in 6 wheels rovers and 8 A/D and D/A converters are used for 8 wheels rovers.

Close loop transfer function of the system: he block diagram shown in figure 4 will contain all the values of the system presented in block diagram in figure 5. After the calculation of the close loop transfer function by using equations (1) and (3) we obtain:

$$T(s) = \frac{G_c(s) \times G(s)}{1 + G_c(s) \times G(s)} \quad (4)$$

After calculation we obtain the final close loop transfer function with k_p, k_i as PI controller variable presented by equation (5).

$$T(s) = \frac{1.14 \times 10^7 (k_i + sk_p)}{s^3 + 3339s^2 + (59700 + 1.14 \times 10^7 k_p)s + k_i 1.14 \times 10^7} \quad (5)$$

We give to $k_p = 0.30, k_i = 50$ then we obtain equation 6:

$$T(s) = \frac{10^7 (0.3078s + 61.56)}{s^3 + 3339s^2 + 3.13 \times 10^6 s + 615.6 \times 10^6} \quad (6)$$

Fig 3 and fig 4 present the time step after and before compensation.

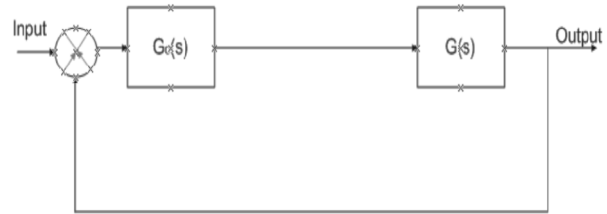

Figure 5: Close Loop Block Diagram

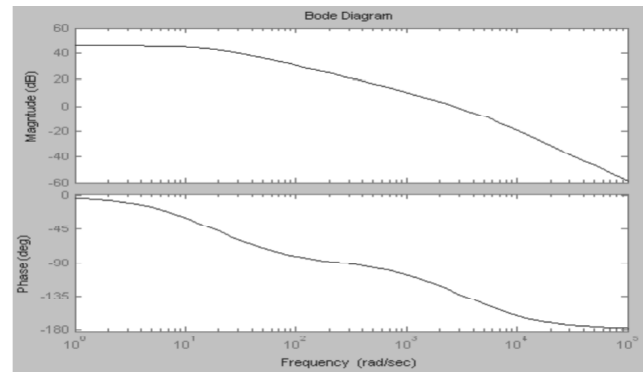

Figure 6: Bode Diagram of the System Before Compensation

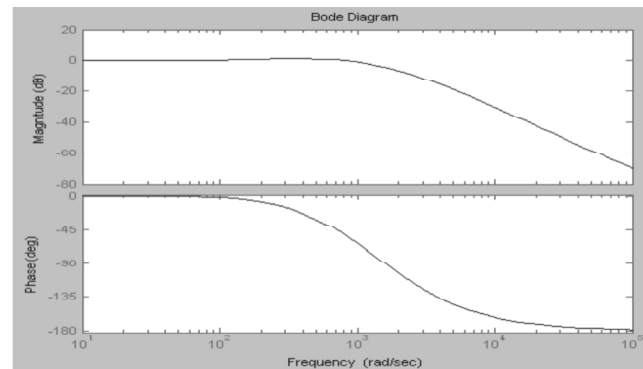

Figure 7: Bode Diagram of the System After Compensation.

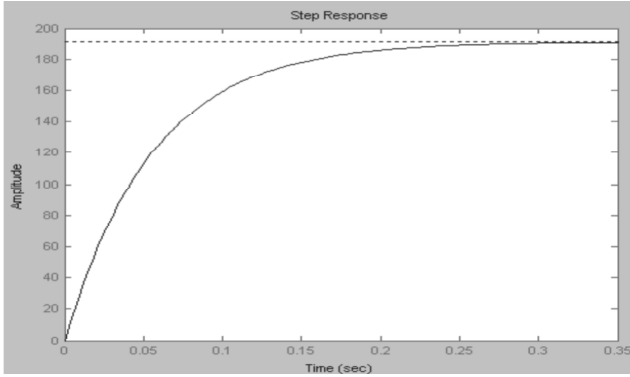

Figure 8: Step Response Before Compensation.

4.2. Discrete Design

The digital Controller was designed by a simple linear to discrete substitution. To find the discrete equivalent of T(S), we use the trapezoidal rule given by equation (7) or Tustin’s method.

$$T(s)^{Tustin}(z) = T(s) \Big|_{s=\frac{2z-1}{Tz+1}} \quad (7)$$

The final equation we found it for discrete design is presented by equation (8) where Figure (10) presents the Bloke diagram of digital system And figure 11 presents the step response of the digital system with sampling time = 0.001s.

$$T(z)^{Tustin} = \frac{0.2397z^3 + 0.2833z^2 - 0.1526z - 0.1961}{z^3 - 1.035z^2 + 0.22z - 0.01076} \quad (8)$$

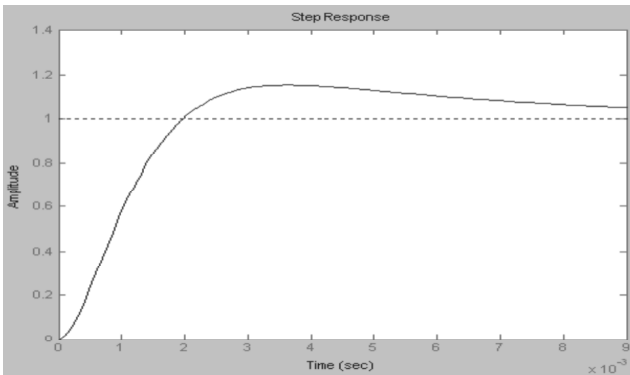

Figure 9: Step response After Compensation.

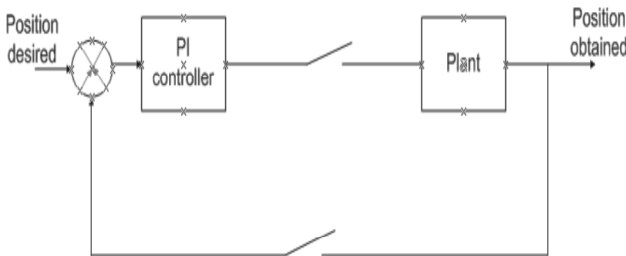

Figure 10: Block Diagram of Digital System.

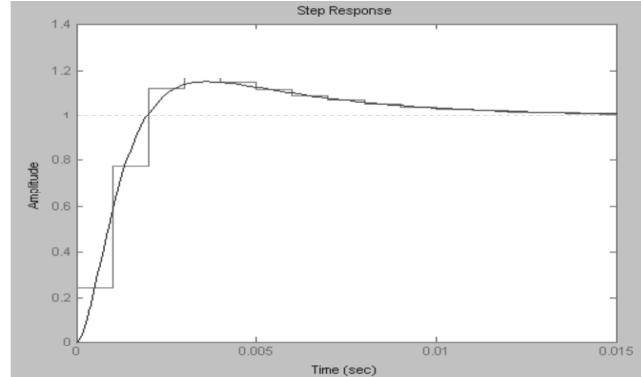

Figure 11: Step Response of the Digital System.

5. CONCLUSION

In this paper we presents the control system design of the digital system presented by the control system design for (2n + 2 / 0 ≤ n ≤ 3) Wheels Mobile Rover. We designed and analyzed the control system of our project by using two method linear method in continues time and discrete method for digital system. We used also PI controller to reduce the steady- state error and have good control system. Tustin method is used to go from linear system to digital system. The control design results are presented by using MATLAB.

ACKNOWLEDGMENTS

The Authors want to say thanks to Huang Rui Nin and Yu ke jie for them collaboration.

REFERENCES

- [1] M. D. Adams D311, 3rd Year Design Course Motion of an Autonomous Mobile Robot: Sensing, Decision & Control Report.
- [2] A. Zerigui Control System Design for Spherical Rover, Master Thesis. Harbin Institute of Technology, Prof. Deng Zong quan.
- [3] A. De Luca, Giuseppe Oriolo, Marilena Vendittelli, Control of Wheeled Mobile Robots: An Experimental Overview, Super Mario report.
- [4] E. Maaloufa, Maarouf Saada, Hamadou Saliab, A Higher Level Path Tracking Controller for a Four-wheel Differentially Steered Mobile Robot, *Robotics and Autonomous Systems* 54 (2006) 23–33.
- [5] P. J. Stooke, Lunar Laser Ranging and the Location of Lunokhod 1. *Lunar and Planetary Science XXXVI* (2005).
- [6] Kenjiro Tadakuma, Matsumoto Masatsugu and Shigeo Hirose, Mechanical Design of Horizontal Polyarticular Expandable 3-wheeled Planetary Rover; “Tri-Star3”, Proceedings of the *IEEE International Conference on Mechatronics & Automation Niagara Falls, Canada* • July 2005. pp. 236–241.

- [7] Roland Siegwart, Miche Lauria, Pierre-Alain Mäusli, Michel Van Winnendael, Design and Implementation of an Innovative Micro-Rover, Proceedings of Robotics 98, the 3rd Conference and Exposition on Robotics in Challenging Environments, Albuquerque, New Mexico, April 26-30, 1998, pp 1-7.
- [8] GordonWyeth, Control Issues for Velocity Sourced Series ElasticActuators, http://www.araa.asn.au/acra/acra2006/papers/paper_5_50.pdf
- [9] Richart C. Dolf, Robert H. Bishop *Modern Control System Book*, Ninth Edition pp. 744-776.
- [10] Gene F. Franklin, J. David Powell, Abbas Amami Naeini. *Feedback Control of Dynamic Systems*, fourth Edition, High Education Press, chapter 6.